

OUTDOOR ENTRY LIGHT

WALL LIGHT MODEL: E1050



- Impact and weather resistant fixture with full polycarbonate housings and lenses.
- Glare free and frosted lens for an inviting and even light distribution.
- Universal mounting plate with integral wire hooks for easy hands free installation.
- Bronze housing finish as stock, special order colors available (white, silver, gray, and black). Call for more information.
- Photocell included with optional photocell cap.
- Name brand chip and DOB technology with a five (5) year warranty.



Dimensions

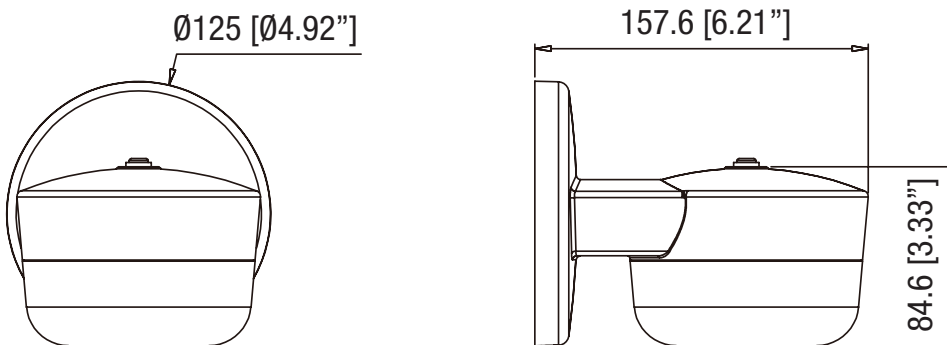

PHOTOMETRY

E1050

Mounting Height=10.00 FT

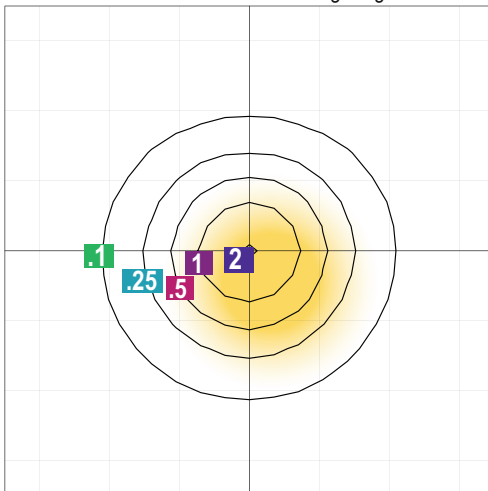

SCALE: 1 INCH = 10 FT.
LIGHT LOSS FACTOR = 1.00

MAXIMUM CALCULATED VALUE = 2.10 FC
FOOT CANDLE = 1 25 5 1 2

Specifications

- Lumens (LM):** 945LM
- Efficacy (LPW):** Up to 80LPW
- Input Voltage:** 120V
- CRI:** >80
- Equivalency (W):** 35W MH
- Operating Temp:** -30-40°C
- Warranty:** 5 Years

WF Harris Lighting, Inc.

Innovative Lighting Designs Since 1970

4015 Airport Ext. Road • Monroe, NC 28110 USA
704.283.7477 (Headquarters) • 800.842.9345 (Toll Free)

E-Mail: customerservice@wfharris.com

www.wfharrislighting.com