

LED WALL/CEILING LUMINAIRE

Model 300-LED-1K Model 300-LED-1K-EM

Rust Resistant
Vandal Resistant
Nonconductive



Energy saving, energy efficient and safe area illumination where style is as important as endurance, dependability and reduced operating costs. The unit delivers the same net lumens in emergency operation as in AC mode. Non-emergency and emergency versions (EM units) of the product are available and allow continuity of aesthetics in multiple luminaire installations, eliminating the need for separate emergency-only units. Emergency mode in the EM luminaire automatically engages on an interruption of power and recharges upon power restoration. Not only do both units meet the challenging issues of indoor/outdoor applications, but also the EM unit in emergency mode exceeds UL924 illumination requirements. Luminaire provides illumination greater than the industry standard 90-minute duration (in excess of 2 hours with new batteries). Vandal resistant. **Quality engineered with materials offering high resistance to rust, corrosion, moisture, dust and impact.** Lens and housing constructed of high impact-resistant polycarbonate is self-extinguishing to assure more safety to the end user. For coastal environments, wharfs and piers, military and civilian housing units, office buildings, schools, hotels/motels, apartments/condominiums, government installations, and other commercial/industrial establishments. Luminaire utilizes high quality LEDs and Driver to further enhance reliability and durability while reducing power consumption.

LEDs contain no mercury and emit no ultraviolet light.

LEDs will not break, unlike conventional lamps, if luminaire is dropped.

Specifications

Lens: Injection molded UV-stabilized **polycarbonate**. Average thickness is .125". Clear Prismatic (Std.) or Opal White lens provides optimal light output and diffusion; smooth exterior surface allows ease of cleaning. Other Lens colors (or Lens color options) available. (See back)

Base Plate: Rust resistant .080" 5052 H-32 tempered marine-grade aluminum.

Housing: Injection molded of UV-stabilized reinforced black, white, or bronze **polycarbonate**. Rear knockout for supply wire. Available in a variety of conduit connections to meet required cord options. (specify placement of and gauge for conduit connections).

Gasket: Lens gasket and mounting gasket are closed-cell neoprene rubber.

LEDs: **High Quality Lighting Grade LEDs**
(Lumen output reduced and softened through Opal White lens)
3000K and 5000K Color Temperature Available
1K (AC) = Net Lumens = 1200 (Efficacy = 120 Lm/W)
Power = 10 W (120-277V)
1K (EM) = Net Lumens = 1200 Power = 14.6 W (120-277V)
Warranted for five (5) years.

LED Life: **Lumen Maintenance (TM-21-11 70% Projection)**
127,000 Hrs (25°C/77°F) = 15 years of 24/7 LED life
95,000 Hrs (50°C/122°F) = 11 years of 24/7 LED life
Calculations Based on US Department of Energy Standards.
DOE TM-21-11, 70%.

Driver: **High Quality Driver**
Class 2 Power Supply.
AC Input: 120-277V, 50/60Hz



Complies with FCC rules and regulations, as per Title 47 CFR Part 15 Non-Consumer (Class A) for EMI/RFI (conducted and radiated) at full load.
Warranted for five (5) years.



Model 300-LED shown in Emergency configuration.

Emergency Battery Pack: Lithium Iron Phosphate battery maintenance free with a life expectancy of 7-10 years and over 90 minutes of emergency lighting. Exterior indicator light reveals that battery is charging during normal operation. During a power interruption, the unit automatically switches to emergency mode. When AC power is restored, the battery is recharged (within 48 hours maximum for a fully discharged battery). In Emergency mode, unit can operate efficiently at temperatures down to 10°C (50°F) and up to 40°C (104°F).
Warranted for five (5) years.

Hardware: Four (4) stainless steel 8-32x3/8 phillips truss head screws or tamperproof screws (must specify) attach lens to base plate. Mounting hardware included.



Model 300-LED in Standard configuration shown with Opal White Lens, Black Housing.



**SBA QUALIFIED
SMALL BUSINESS MANUFACTURER**

TAA COMPLIANT
TRADE AGREEMENT ACT COMPLIANT

ETL-US and ETL-C Listed (UL1598)

All polycarbonate components meet Underwriters Laboratories 746C tests for polymeric material and carry a flammability rating of 94HB or better on lenses and the superior 94-5V rating on housings.

Luminaire Type _____
Catalog Number _____
Product Code _____
Job Name _____
Approval _____

WF Harris Lighting, Inc.™

Innovative Lighting Designs Since 1970

P.O. Box 5023, Monroe, NC 28111-5023, USA
704.283.7477 (HEADQUARTERS) • 800.842.9345 (TOLL FREE)

e-mail: customerservice@wfharris.com
www.wfharrislighting.com

Form 2502-2BJ

"A Live Operator Company Standing Ready to Serve Your Lighting Needs."

LED WALL/CEILING LUMINAIRE

Ordering Information

Fill In Blocks For Complete Catalog Number

300-LED	-		-		-	
Model		Lens Color		Housing Color		Options
300-LED-1K 300-LED-1K-EM		CP - Clear Prismatic (Std.) OW - Opal White A - Amber G - Green		HK - Black Housing HW - White Housing HB - Bronze Housing		CRS - Conduit Connection Right Side ^{1,2} CLS - Conduit Connection Left Side ^{1,2} CT - Conduit Connection Top ^{1,2} CB - Conduit Connection Bottom ^{1,2} C4 - Conduit Connections All 4 Sides ^{1,2} TPS - Tamperproof Screws (4) ²

Accessories

(Order Separately)

TPT-Tamperproof Screwdriver



¹ Positions Based on Facing Luminaire.

² Additional Charge.

³ Consult Factory for Availability.

Dimensions

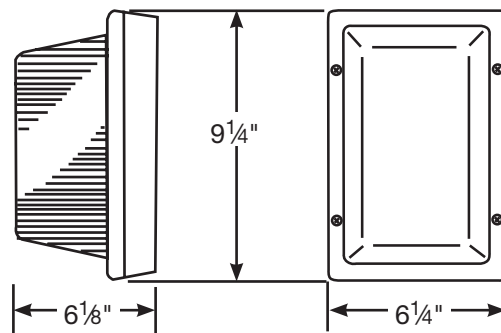

Weight

300-LED-1K = 2.8 lbs.

300-LED-1K-EM = 4.5 lbs.

LEDs and the W. F. Harris Lighting Advantage

The lighting grade LEDs used by W. F. Harris Lighting provide the long sought-after stability demanded for commercial illumination in brightness, efficacy, and life time. Can be used in commercial/industrial illumination applications, hospitals, schools, universities, government buildings, military installations and freezer applications.

W. F. Harris Lighting LED-based luminaires reduce ownership costs through five factors –

- (1) Maintenance avoidance – LEDs last much longer than traditional lamps plus the luminaire is rust resistant and vandal resistant.
- (2) Reduced energy cost of the LEDs.
- (3) Reduced cost in operation of freezer compressors due to lower wattage and less heat in standard mode.
- (4) LEDs will not break, unlike conventional lamps, if luminaire is dropped.
- (5) LEDs contain no mercury and emit no ultraviolet light.

These lighting grade LEDs offer efficient illumination that - depending on the application - can last up to 84,000 hours before their light output falls below 70% of original illumination and even longer in refrigerated environments.



**SBA QUALIFIED
SMALL BUSINESS MANUFACTURER**

TAA COMPLIANT
TRADE AGREEMENT ACT COMPLIANT

**LENS AND HOUSING CARRY A LIFETIME
WARRANTY AGAINST BREAKAGE.**

Specifications Subject to Change Without Notice.

W.F. Harris Lighting, Inc.™

Innovative Lighting Designs Since 1970

P.O. Box 5023, Monroe, NC 28111-5023, USA

704.283.7477 (HEADQUARTERS) • 800.842.9345 (TOLL FREE)

e-mail: customerservice@wfharris.com

www.wfharrislighting.com

© 2019 W. F. Harris Lighting, Inc.

Printed in USA

Form 2502-2BJ

"W. F. Harris Lighting Will Not Sacrifice Quality for the Sake of Price."